

Design and fabrication of Oil Extraction Machine from Nuts

By

Abdul-Akaba Tijani, Kantiok Obadiah, Haruna Abubakar

Department of Mechanical Engineering, Kaduna Polytechnic Kaduna, Nigeria.

Abstract.

This project is aimed at the design and fabrication of oil extraction machine from nuts. The objectives are aimed at providing a base for the commercial production of the machine, using locally available raw materials at a relatively low cost. There is so much wastage of these nuts on farms since a negligible portion is consumed by the harvesters. This work is intended to help solve some of the problems hindering a successful design and fabrication of oil extraction machine from nuts.

Key words: Nuts, Extraction, Machine, Fabrication.

Introduction

Nigeria agricultural resources are vast and the progressive harnessing of the resources will result in substantial improvement in output. Nuts generally are economic crops in Nigeria and it has been grown in small plantations in some states like Anambra, Imo, Kwara, Oyo, Edo and Lagos, and to a lesser extent in Ogun, Osun, Delta, Ondo, Niger and other states. For example in 1994, cashew nuts accounted for ₦156.1 millions of non-oil export earnings in Nigeria which increased to ₦743million (US7.43m) in 1995 (CBN Annual Report, 1997). There is no doubt that with considerable increase in planted areas and further increase in world demand for cashew, kernels, and the cashew industry will continue to expand. However, despite the increase in production, it is only the cashew nut that is mostly utilized in the processing industry. There is so much wastage of the fresh cashew apple due to its perishable nature. To reduce this waste, it was thought worthwhile to access the utilization of this material for human consumption in local cottage industries.

This research was set out to establish possible extraction of oil from its nuts and to improve processing procedure, market value and quality of the derived products from the nuts. The overall objective of the work is to design, construct and evaluate the performance of simple and compact equipment for oil extracting machine from nuts.

Materials and Methods

Equipment Description

The oil extracting machine from nuts consist of cylindrical head with feeding hopper, the machine housing(casing), rotating shaft, flange, electric motor seat, bearings and pulley system. The feeding hopper holds the nuts for extracting processes. The material to be used for fabrication were selected after careful study of the desired physical, mechanical and chemical and even aesthetic characteristics of a number of proposed material. For this project, due to economical considerations and availability of raw materials, high and medium carbon steel was mostly used for body parts and chuck materials while cast iron was chosen for the pulley, Kurmi and Gupta (2004). The machine housing is also made of 1.5mm mild steel sheet and it houses the rotating shaft. The machine operates with a screw shaft to grind and extract the oil from the nuts. The solid drive shaft protrudes out and a pulley fixed at one end.

Design Analysis

Determination of cylindrical feed hopper capacity

The volume of the hopper = $\pi \times r^2 \times h$ 1

Where h = height/ length of hopper

r= radius of hopper

Belt and pulley design

The design and selection of appropriate power requirement for the rotation of the depulping stirring unit was selected based on the speed of the driving motor, speed reduction ratio, centre to centre distance between the shafts at the

condition under which the depulping action must take place. An ac motor with 1410 rev/min(24 rev/s)was used with a pulley diameter of 50mm.The depulping stirring unit of 282 rev /min (5 rev /s)is desired. A low speed of shaft rotation is expected during extracting operation since the stirring unit must be operated within a fluid medium in an enclosure. The diameter of a pulley for the driven shaft is calculated using the equation for the peripheral speed of the belt as shown in eqn.2 (Kurmi and Gupta,).

$$\pi d_1 N_1 = \pi d_2 N_2 \quad 2$$

Where,

d_1 =pulley diameter of electric motor (mm)

N_1 =speed of the electric motor (rpm)

d_2 =pulley diameter of stirring unit (mm)

N_2 =speed of rotating the stirring unit (rpm)

Determination of belt length

The belt length was obtained as given by

$$L = 2C + \frac{\pi}{2}(D_1 + D_2) + \frac{D_1 - D_2}{4C} \quad \text{(Khurmi and Gupta 2005)} \quad 3$$

The centre to centre distance between driving and driven pulley is given as

$$C = 2(D_1 + D_2) \quad 4$$

Where D_1 and D_2 are the diameters of the pulley respectively

C = center to center distance between the driving and driven pulley

To obtain the speed of driving and driven pulley

$$V_1 = \frac{\pi D_1 N_1}{60} \quad 5$$

$$V_2 = \frac{\pi D_2 N_2}{60} \quad 6$$

Where N_1 and N_2 are the revolutions per minute for the driving pulley and driven pulley respectively.

Lap Angle

The equation is given by

$$\alpha_1 = 180 - 2 \sin^{-1} \left(\frac{D_2 - D_1}{2C} \right) \quad 7$$

$$\alpha_2 = 180 - 2 \sin^{-1} \left(\frac{D_2 - D_1}{2C} \right) \quad 8$$

Where

α_1 = the angle of lap for driving pulley (rad)

α_2 = the angle of lap for driven pulley

C = Centre to centre between driving driving pulley and driven pulley (mm)

Determination of belt tensions

$$P = (T_1 - T_2)V \quad 9$$

Where, P= belt power (W),

T_1 and T_2 are tensions on the tight and slack sides respectively (N)

Using belt ratio for an open belt,

$$\left(\frac{T_1}{T_2} \right) = e^{f\alpha} \quad 10$$

Where f = coefficient of friction between belt and pulley.

Shaft Design

The shaft of the machine carries a pulley that receives power from an electric motor via V-belt, the extracting shaft and bearings.

The minimum shaft diameter needed to avoid failure of shaft is calculated as follows:

Torque on the shaft

The power is delivered to the shaft by some tangential force and the resultant torque (twist moment) set up within the shaft permits the power to be transferred to various machine components linked up to the shaft.

$$\text{The torque, } T = \frac{\text{power}}{\text{Angular Acceleration, } \omega} \quad 11$$

$$\text{Where } \omega = \frac{2\pi N}{60} \quad 12$$

$$\text{Torque, } T = \frac{P}{\omega} = \frac{P \times 60}{2\pi N} \quad 13$$

$$\text{Equivalent twist moment } T_e = \frac{\pi}{16} \times \tau \times D_s^3 \quad 14$$

Where, τ = permissible shear stress of material

D_s = diameter of shaft

$$\text{But, } T_e = \sqrt{M^2 + T^2} \quad 15$$

Where M = bending moment

$$D_e N_d = D_d N_e \quad 16$$

D_e = diameter of the driver pulley

D_d = diameter of the driven pulley

N_e = speed of the driver in rpm

N_d = speed of the driven in rpm

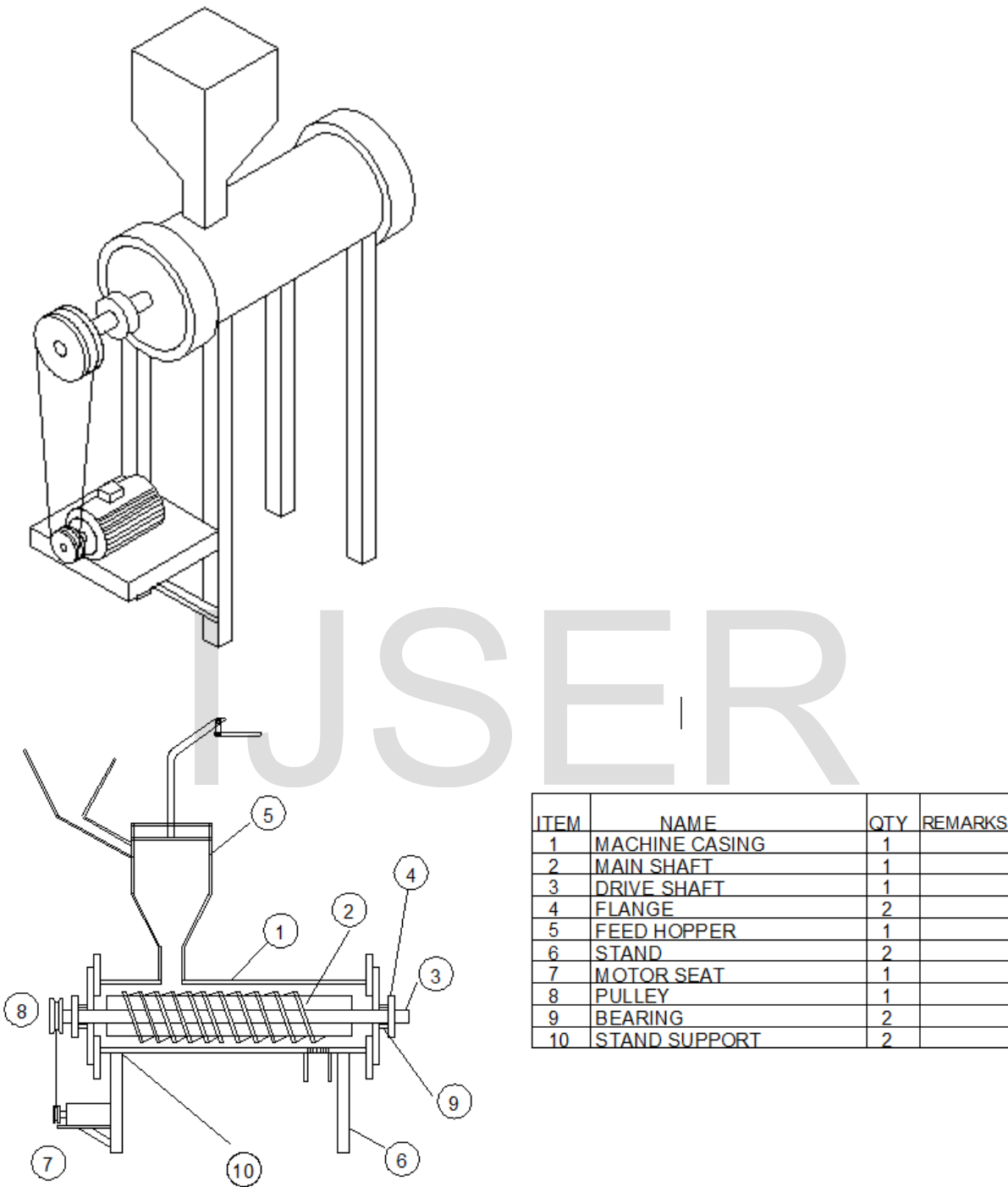

Fig 1: The oil extracting machine

Fabrication Processes

The manufacturing process used in fabrication of the oil extracting machine from nuts is such that the total cost of fabrication is reduced and also one that can make use of the available materials. The manufacturing process involved in this work includes, joining of metal parts by welding, cutting using hacksaw and hand cutting machine. Each component of the machine is fabricated separately before joined or welded together as the case may be. The following are the procedure of fabrication of each component of the machine and final assembly.

The Frame

The machine frame supports the other parts of machine as well as providing balance. It subjected to direct weight or load of other member of the machine (hence compressive force) and also to torque and vibration from the machine. The desired material should be of high rigidity, hardness, adequate toughness. For this purpose high carbon steel rod were chosen.

The body

The covers the entire moving parts of the machine. It also provides support and balance for the machine. It made of medium carbon steel because of its machineability, hardness and rigidity.

Pulley

The pulley is attached to the rotating shaft. It should be rigid, hard and machineable. Cast iron was chosen for this purpose as the pulley would be subjected to tension forces from belt.

Conclusion

The oil extracting machine from nuts was fabricated from the available locally source materials. The machine is very applicable for local production, operation, repair and maintenance. The operation of the machine which could be manually or electrically operated makes it unique type compare to others. The automatic operation of the machine saved energy and did not required high skilled labour.

The operational and process performance showed that the machine extract well over an average of 62% of nuts when manually and electrically operated.

Finally, the operation is simple, save time and energy. It can be used in rural areas where electricity is not available.

References

Adigun, Y.J and Alonge, A.F.(2000), some engineering properties of Shea Nut relevant to mechanical processing. *Ife journal of Technology (NIJOTECH)*, 19(1): 51-59

Biotechnol,Vol.4 no.8. pp 812-815.2005.

CBN (1997) Central Bank of Nigeria Annual Report and statement of Account, 31st December, 1997.

D.A Alabi, O.R Akisulire, and M.A Sanyanolu. Quantitative Determination of Chemical and Nutritional Composition of *Parkia Biglobosa*(jacq).*Afr. J.*

Khurmi, R.J and Gupta, J.K (2005) a text book of machine design, New Delhi-110055, Eurasia Publishing House.

O.O.Oduwale, T.O.Akinwale (2001), Economic evaluation of a locally fabricated extraction machine for a cottage cashew juice factory. *The journal of food technology in Africa*, vol.6 No.1

Spots, M.F and Terry E. (2003), *Design of machine elements*, Pearson Prentice Hall, 8th Edition

UNO. Food and nutrition bulletin. Vol.18, no.4, 1997. Pp 102.

M.S Teota and T. Ramakrishm. "Densities of meleon seed, kernels and fluids."
Journal of Food Engineering. Vol.3, no1,1989.pp 231-236.

M. Beaumont. Flavoring Composition Prepared by Fermentation with Bacillus
spp. Int. J. Food Microbiol.Vol.75.pp 189-196.2002.

IJSER